



**APPLICATION FOR ZONING PERMIT**  
**Village of Jackson Center**  
**Shelby County, Ohio**

(For Office Use Only)

Application # \_\_\_\_\_

Property Zoned As: \_\_\_\_\_

Date: \_\_\_\_\_, 20\_\_\_\_

The undersigned applies for a Zoning Permit for the following use. Said permit to be issued on the basis of the information contained within this application. The applicant hereby certifies that all information and attachments to this application are true and correct. The responsibility of the knowing and / or proving the location of the property line falls on the property owner of the property that is being altered by construction or the owner applying for a zoning permit. The Village may assist with the location of property pins when personnel are available but are in no way responsible for the accurate location of any pins or property lines. **The applicant is responsible for meeting the guidelines for surface water runoff as addressed in the Village of Jackson Center Subdivision Regulations with NO land altering activity that will disperse runoff into contiguous properties.** (Section 600.20)

**1) Location Description** (If not located in a platted subdivision, attach a legal description.)

Street Address: \_\_\_\_\_

Subdivision Name: \_\_\_\_\_

Lot No. \_\_\_\_\_ Outlot No. \_\_\_\_\_ Acres: \_\_\_\_\_ Parcel: \_\_\_\_\_

Lot Size:      Width \_\_\_\_\_      Depth \_\_\_\_\_      Area \_\_\_\_\_

**2) Name of Owner (s):** \_\_\_\_\_

Mailing Address: \_\_\_\_\_

Phone No.:      Home: \_\_\_\_\_      Cell: \_\_\_\_\_      Work: \_\_\_\_\_

Contractor: \_\_\_\_\_      Estimated Cost: \_\_\_\_\_

**3) Existing Use:** \_\_\_\_\_

**4) Proposed Use:**

Residential \_\_\_\_\_ Commercial \_\_\_\_\_ Industrial \_\_\_\_\_

Fence \_\_\_\_\_ Accessory Structure \_\_\_\_\_ Swimming Pool \_\_\_\_\_ Sign \_\_\_\_\_

**5) Residential Use:** (Sketch layout on Page # \_\_\_\_\_ : (Page 3 for Interior Lot or Page 4 for Corner Lot)

No. of Residential Units \_\_\_\_\_ New Construction \_\_\_\_\_ Addition \_\_\_\_\_ Alteration \_\_\_\_\_

Size:      Story \_\_\_\_\_      Width \_\_\_\_\_      Length \_\_\_\_\_      Height \_\_\_\_\_

Living Area: \_\_\_\_\_ Sq. Ft.      Garage: \_\_\_\_\_ Sq. Ft.      Basement: \_\_\_\_\_ Sq. Ft.

Setbacks Required:      Front Yard: \_\_\_\_\_      Side Yard: \_\_\_\_\_      Rear Yard: \_\_\_\_\_

**APPLICATION FOR ZONING PERMIT Cont'd.**

**6) Commercial or Industrial Use:** (Attach Building Plans in Duplicate.)

New Construction: \_\_\_\_\_ Addition \_\_\_\_\_ Alteration \_\_\_\_\_

Size: Story \_\_\_\_\_ Width \_\_\_\_\_ Length \_\_\_\_\_ Height \_\_\_\_\_

Number of off-street parking spaces provided: \_\_\_\_\_

Number of off-street loading berths or docks to be provided: \_\_\_\_\_

Site Plan submitted in duplicate, drawn to scale showing actual dimensions and shape of lot with exact sizes and location of uses?

Yes \_\_\_\_\_ No \_\_\_\_\_

Building Plans submitted in duplicate, drawn to scale? Yes \_\_\_\_\_ No \_\_\_\_\_

Setbacks Required: \_\_\_\_\_ Front \_\_\_\_\_ Side \_\_\_\_\_ Rear \_\_\_\_\_

**7) Accessory Use:**

Fence \_\_\_\_\_ Accessory Structure \_\_\_\_\_ Swimming Pool \_\_\_\_\_ Other \_\_\_\_\_

Dimensions: Height: \_\_\_\_\_ Length: \_\_\_\_\_ Width: \_\_\_\_\_ Size: \_\_\_\_\_

**8) Signage:**

Dimensions: Height: \_\_\_\_\_ Length: \_\_\_\_\_ Width: \_\_\_\_\_ Size: \_\_\_\_\_

Sketch of Sign and location on lot attached? Yes \_\_\_\_\_ No \_\_\_\_\_

**9) Zoning Permit Fee paid?**

Yes \_\_\_\_\_ No \_\_\_\_\_

**10) Submitted to Shelby County Health Department (Building Permit)?**

Yes \_\_\_\_\_ No \_\_\_\_\_

**11) Signature of Owner:** \_\_\_\_\_ **Date:** \_\_\_\_\_

**NOTE: This permit shall be void if work is not started within one (1) year or completed within two (2) years.**

(Space below reserved for office use only.)

**Date Filed:**

(Date Stamp or Attach Receipt.)

**Issued:** \_\_\_\_\_ **,20**

**Denied:** \_\_\_\_\_ **,20**

**Signed:** \_\_\_\_\_ **,20**

**Zoning Enforcement Officer**

# SKETCH LAYOUT FOR APPLICATION FOR ZONING PERMIT INTERIOR LOT

Application No. \_\_\_\_\_

Owner: \_\_\_\_\_ Address \_\_\_\_\_

Lot No.: \_\_\_\_\_

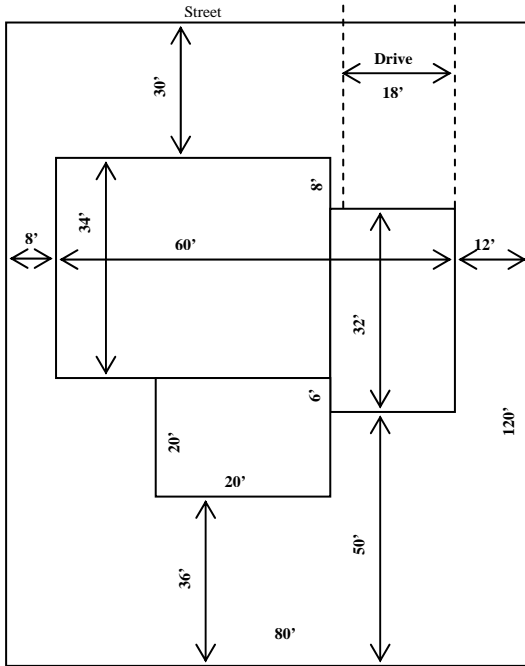

Indicate below exactly what you plan to build, giving all dimensions as shown in Typical Sketch at left. It need not be drawn to scale. Show the planned off-street parking you will provide.

The Village Staff will help with lot numbers, name of subdivision, and lot dimensions as the official tax maps have it recorded. If your deed should indicate otherwise, it will be your responsibility to establish the difference.

Description of improvements as follows:

---



---



---



---



---

Space below to be used by Applicant

---

Date \_\_\_\_\_

Signed: \_\_\_\_\_

Applicant Property Owner

# SKETCH LAYOUT FOR APPLICATION FOR ZONING PERMIT CORNER LOT

Application No. \_\_\_\_\_

Owner: \_\_\_\_\_ Address \_\_\_\_\_

Lot No.: \_\_\_\_\_

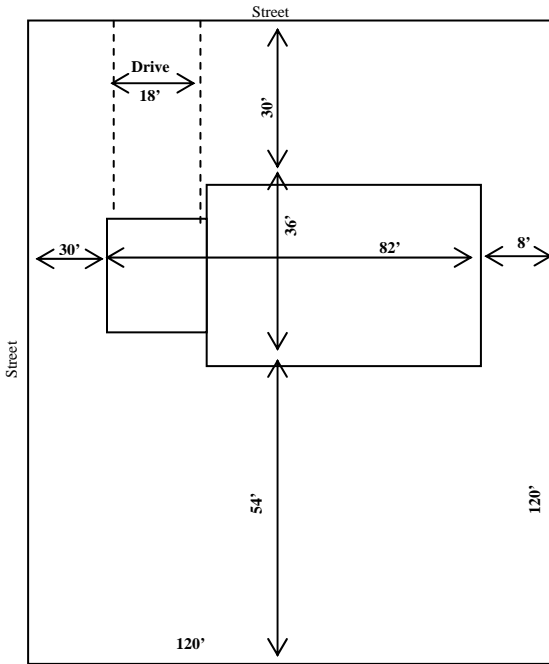

Indicate below exactly what you plan to build, giving all dimensions as shown in Typical Sketch at left. It need not be drawn to scale. Show the planned off-street parking you will provide.

The Village Staff will help with lot numbers, name of subdivision, and lot dimensions as the official tax maps have it recorded. If your deed should indicate otherwise, it will be your responsibility to establish the difference.

Description of improvements as follows:

\_\_\_\_\_

\_\_\_\_\_

\_\_\_\_\_

\_\_\_\_\_

\_\_\_\_\_

Space below to be used by Applicant

---

Date \_\_\_\_\_

Signed: \_\_\_\_\_  
Applicant Property Owner